



---

SS-Series Shrink Tunnels  
Model: ST-1808-44

**Distributed By:**

Version 1.0  
Last Updated: 2/21/20

Copyright © 2019 by Stephanie Hwang

All rights reserved. No part of this publication may be reproduced, distributed, or transmitted in any form or by any means, including photocopying, recording, or other electronic or mechanical methods, without the prior written permission of the publisher, except in the case of brief quotations embodied in critical reviews and certain other noncommercial uses permitted by copyright law. For permission requests, write to the publisher, addressed "Attention: Permissions Coordinator," at the address below.

Sealer Sales, Inc.  
8820 Baird Avenue  
Northridge, Ca 91324  
[www.sealersales.com](http://www.sealersales.com)

Printed in the United States of America

**ST-1808-44 Tunnel Service Manual**

---

---

**IMPORTANT - PLEASE READ THIS CAREFULLY**

The development of a good safety program, that is rigidly enforced, is absolutely imperative when involved in the operation of industrial equipment. Our machinery is well designed and includes extremely important safety features. The part you the user play through proper installation and maintenance procedures is of far greater significance than our designs. Only properly trained individuals following rigidly enforced safety rules, as recommended by A.N.S.I. and O.S.H.A., should be allowed to operate these machines.

**ST-1808-44 Tunnel Service Manual**

---

**TABLE OF CONTENTS**

---

**Preface**

Unpacking	4-8
Warranty Notice	9
Warranty	10-11
Warranty Exceptions	12
Warnings	13-15

**Tunnel Section**

Description and Specifications	16
Installation and Basic Set-Up	17-18
Front Panel Diagram	19
Sequence of Operation	20-22
Temperature Control Adjustment	23
Troubleshooting	24-33
Troubleshooting—Conveyor Malfunction	25-28
Troubleshooting—No Air Flow	28-30
Troubleshooting—No Heat	31-33
Maintenance	34-49
Maintenance—Replace Conveyor Rollers	35-37
Maintenance—Replace Idler Shaft	38
Maintenance—Replace Drive Shaft	39
Maintenance—Replace Conveyor Motor	40
Maintenance—Replace Heater Bank	41-42
Maintenance—Replace Temperature Controller	43
Maintenance—Replace Blower Motor	44-46
Maintenance—Replace Wear Rails	47-49
Electrical Panel Diagram	50
Electrical Schematic	51
Parts List Nomenclature	52
Replacement Parts List	53-55
Spare Parts List	56

**ST-1808-44 Tunnel Service Manual**

---

**UNPACKING****THOROUGHLY INSPECT EQUIPMENT UPON ARRIVAL.**

If goods are received short or in a damaged condition, it is important that you notify the carrier's driver **before he leaves your company** and **insist** on a notation of the loss or damage across the face of the freight bill. Unless this is done, no claim can be enforced against the transportation company.

If concealed loss or damage is discovered, notify the carrier at once and **insist** on an inspection. This is absolutely necessary! A concealed damage report must be made no later than ten (10) days from the date the shipment was delivered. Unless you do this, the carrier will not consider any claim for loss or damage. The carrier's agent will then make an inspection and grant a concealed damage notation. If you give the transportation company a clear receipt for the goods that have been damaged or lost in transit, you do so at your own risk and expense.

All claims must be filed within 10 days of delivery date or carrier will not accept them.

Sealer Sales is willing to assist in every possible manner to collect claims for loss or damage; however, this does not hold Sealer Sales responsible for collection on claims or replacement of material.

Do not throw away damaged pallets or box until freight inspection has occurred.

**ST-1808-44 Tunnel Service Manual**

---



Your new Tunnel comes bolted to a pallet and has a tri-walled corrugated box strapped to the pallet to protect the tunnel.

If your machine does not arrive in this condition, **write on shipping paperwork that outside of box is damaged. Concealed damage may have occurred.**

**ST-1808-44 Tunnel Service Manual**

---

**UNPACKING**



1. Cut the two steel straps holding corrugated box to pallet.
2. Remove tri-wall corrugated box from pallet.

**ST-1808-44 Tunnel Service Manual**

---

**UNPACKING**



3. Remove plastic bag and stretch film that covers machine.



4. Unbolt tunnel from base of pallet using 13mm wrench.
5. Place forks of forklift under center of tunnel to lift off the pallet.
6. Place in desired location and use leveling bolts to match your sealer height.

## ST-1808-44 Tunnel Service Manual

---

### UNPACKING

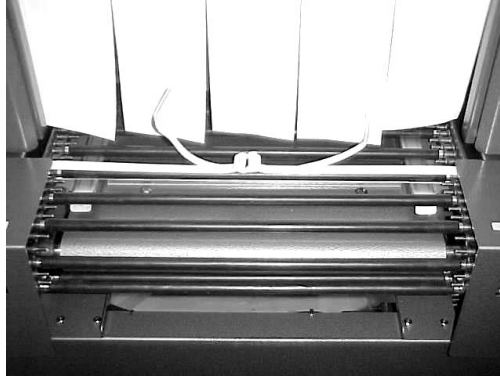

7. Cut plastic strap from **top and bottom** of conveyor rollers before attempting to operate conveyor.

**ST-1808-44 Tunnel Service Manual**

---

**IMPORTANT WARRANTY NOTICES****OPERATING AND MAINTENANCE MANUAL**

The operating and maintenance manual has been carefully prepared to provide the user with all the information needed to properly install, operate, and maintain your equipment.

Please read this manual carefully and refer to it for information on the care and use of your equipment. It is recommended that additional copies be ordered for use by production, maintenance, and supervisory personnel. Although the design of this equipment incorporates safeguards to protect personnel, care should be used in operating, adjusting, and servicing.

Attention is directed to the warranty that accompanies all your equipment. The terms and conditions of this warranty apply only to unmodified units. **Any unauthorized modifications to the equipment automatically voids this warranty.**

**ST-1808-44 Tunnel Service Manual**

---

## Sealer Sales

# WARRANTY

Sealer Sales, Inc. warrants each new product manufactured to be free from defects in material and workmanship for a period of (1) year from date of shipment by Sealer Sales.

This warranty is not transferable with any subsequent resale.

Defective parts under warranty must be returned to Sealer Sales freight prepaid. Sealer Sales' sole obligation and purchaser's sole remedy in the event of a warranty dispute shall be, at Sealer Sales' option, to repair or replace the part in question. Labor incurred in removing or installing the defective part is not covered by this warranty. Prior to returning any parts for any reason, contact Sealer Sales for a Return Authorization Number. This number must accompany all returns.

This warranty shall not apply if equipment has been tampered with, misused, improperly installed, altered, or has received damage due to abuse, carelessness, accident or failure to follow recommended regular maintenance procedures or has been serviced by someone other than a duly authorized factory representative without the express written consent of Sealer Sales, Inc.

This warranty is in lieu of all other warranties, expressed or implied, including but not limited to warranties of merchantability and fitness for a particular purpose, non-infringement or any other matter.

**ST-1808-44 Tunnel Service Manual**

---

Sealer Sales shall have no liability to any person for direct, indirect, incidental or consequential damages or delay resulting from any defect negligence, or tort and customer hereby waives for itself any and all claims for punitive damages and all claims of negligence of strict liability or both. In no event shall our liability exceed the purchase price of the product that was actually paid.

Sealer Sales reserves the right to make changes, additions, or improvements to our products with no obligation to make such changes in any previously shipped product covered by this warranty.

Sealer Sales shall not be held liable for any damages arising out of nor in connection with the operation of the equipment should customer or its agent fail to maintain equipment in safe operating condition. This warranty shall become unenforceable if and to the extent the customer or its agents remove, disconnect, or otherwise render useless any safety device and or parts designed or affixed by us or fails to maintain and service equipment in a manner as advised.

**Sealer Sales provides a two-year warranty on parts, excluding shipping or freight costs for replacement parts. All warranty parts are shipped F.O.B. Rancho Cucamonga, California. Service Labor to install part is not covered under warranty!**

**ST-1808-44 Tunnel Service Manual**

---

---

**WARRANTY EXCEPTIONS**

The following parts are an exception to the general warranty list on page 10. Each part listed below shall carry a 30-day warranty unless designated otherwise.

ST-1808-44 Tunnel Parts

1. Silicone Tubing (roller covers)
2. Tunnel Curtains

**ST-1808-44 Tunnel Service Manual**

---

# **WARNINGS**

Every effort has been taken to ensure your safety while operating this machine; however, there still remain certain risks. Do not allow this machine to be operated before informing all personnel of the following warnings.

**WARNING.....**

Do not tamper with the electrical wiring. Only use a licensed electrician for maintenance. Always disconnect the electrical power before attempting any maintenance to all electrical and/or moving parts.

**WARNING.....**

In order to prevent injury to personnel and/or machinery **DO NOT INCREASE SETTINGS OR RATINGS ON EITHER ELECTRICAL OR MECHANICAL OVERLOAD SAFETY DEVICES.**

**WARNING.....**

**KEEP HANDS AWAY FROM MOVING CONVEYORS AND ASSEMBLIES.** Conveyor belts that have become worn or frayed are capable of being hazardous. They should be replaced promptly.

**WARNING.....**

**NEVER OPERATE THIS OR ANY MOVING EQUIPMENT WITHOUT ALL COVERS AND GUARDS IN PLACE.** The internal mechanism of most packaging machinery contains numerous shear, pinch, and inrunning nip points, many of which are capable of causing severe injury and/or permanent disfigurement.

**ST-1808-44 Tunnel Service Manual**

---

**WARNING.....**

To minimize the potential for personnel injury, always be sure that machine operators and others working on the machinery are properly trained in the correct usage of the equipment and properly instructed regarding the safety procedures for operation.

**WARNING.....**

Heat sealing arms and jaws on packaging machinery can become very warm after a period of use. KEEP HANDS AWAY WHILE IN OPERATION AND USE CAUTION IF THE MACHINE HAS BEEN RUNNING RECENTLY.

**WARNING.....**

ANY MODIFICATIONS TO EITHER THE ELECTRICAL CIRCUITRY OR THE MECHANICAL ASSEMBLIES OF THE MACHINERY WILL VOID ANY WARRANTIES ASSOCIATED WITH THIS EQUIPMENT. Such modifications may introduce hazards that would not otherwise be associated with this machinery. Sealer Sales will not be responsible for any consequences resulting from such unauthorized modifications.

**WARNING.....**

The use of certain types of plastic films in sealing and/or shrinking equipment may result in the release of HAZARDOUS FUMES due to the degradation of the film at high temperatures. Before using any plastic film in this equipment, the manufacturer or supplier of the film should be contacted for specific information concerning the potential release of hazardous fumes. ADEQUATE VENTILATION MUST BE PROVIDED AT ALL TIMES.

**ST-1808-44 Tunnel Service Manual**

---

**WARNING.....**

It is important that the machine operator unplug the machine when he/she has finished operating the unit.

**WARNING.....**

Turn off machine and disconnect power cord from power source before attempting to make any repairs or work on machine.

**ST-1808-44 Tunnel Service Manual**

---

**DESCRIPTION AND SPECIFICATIONS OF  
MODEL ST-1808-44 TUNNEL**

**DESCRIPTION**

The ST-1808-44 Tunnel is a conveyORIZED heat shrinking device employing electric heating combined with a recirculating air system, and a complete range of adjustments. The main components are the blower, the heater bank, the shrink chamber, and the package conveyor. Curtains cover the entrance and exit of the heat chamber to minimize heat loss as packages travel through the tunnel. This is a live roller tunnel. High-density kits are available on request, to provide 1/2" spacing between rollers to accommodate small packages and special applications. Teflon mesh belt kits are also available.

A simple yet reliable and extremely durable shrink tunnel. The strength and durability of this model are it's greatest features. Straightforward, easy manual operation is employed. Operator training should, at the ultimate extreme, be less than one work shift.

**SPECIFICATIONS**

Model:	ST-1808-44
Chamber Size:	Length: 44" Width: 18" Height: 8"
Volts:	220
Amperage:	40
Phase:	Single 1/0
Weight:	500 lbs.

**ST-1808-44 Tunnel Service Manual**

---

---

**INSTALLATION AND BASIC SET-UP****IMPORTANT**

Read this manual carefully, and make it available to everyone connected with the supervision, maintenance, or production of this machine. Additional copies are available at your request. (Contact your distributor for this information.) Be very careful when operating, adjusting, or servicing this equipment. If in doubt, stop and obtain qualified help before proceeding.

**INSTALLATION OF SHRINK TUNNEL**

Place the tunnel in the desired location with the required electrical power source available. (See power requirements.) Make certain that proper electrical wiring is provided to guard against low voltage. If the voltage is too low, the equipment will not function properly.

Finding the proper location is a most important function of the initial set-up. One must take several factors into consideration:

1. Adequate power source.
2. Relationship to source of product.
3. Relationship to sealer.
4. Relationship to any conveyors necessary to remove finished product.
5. Convenience of operator.
6. Avoid drafty areas as heat may be unintentionally drawn from the tunnel and reduce its efficiency.

An electrician should install a plug on the end of the main power cord. If there is any doubt, get qualified assistance to do the initial installation. **Do not take any chances!**

**ST-1808-44 Tunnel Service Manual**

---

Do not attempt to install, adjust, or operate this machine without first reading the contents of this manual. Although the design of the equipment incorporates safeguards to protect operating and maintenance personnel, care should be used in operating, adjusting, and servicing.

ST-1808-44 Tunnel Service Manual

---

-- Front Panel Diagram



1. Start Switch -- Green
2. Heater Switch -- White
3. Conveyor Speed Control – Small Black Knob
4. Digital Temperature Control
5. Air Velocity Control – Large Black Knob

**ST-1808-44 Tunnel Service Manual**

---

**SEQUENCE OF OPERATION**



- A. Turn the tunnel on by flipping the main breaker switch to the **ON** position at rear of the machine.

**ST-1808-44 Tunnel Service Manual**

**SEQUENCE OF OPERATION**



- A. **Turn the START switch** (1) to the on position to start the machine. (Temperature will be displayed on temperature control at this time. This will also start the cooling fan motor.)
- B. **Turn the HEATER switch** (2) the on position, this will start the blower, conveyor motors and heater.
- C. **Set the Conveyor Speed Control** (3) to about mid-range until the exact desired conveyor speed is determined later (based on package size and sealer speed). Factory setting is 4.
- D. **Set the Temperature Controller** (4) at the temperature you believe will shrink your product. This temperature may need to be adjusted higher or lower until you have achieved the shrink you are happy with for that product. As long as you are

**ST-1808-44 Tunnel Service Manual**

---

running the same product, this temperature should not have to be adjusted again. Factory setting is 290 degrees.

**SEQUENCE OF OPERATION**

- E. **Turn Air Velocity Control knob** (5) to high. Most tunnel applications will use high air velocity. You may lower the Air Velocity for (a) lightweight packages that may lift or float from excess air pressure or (b) should you want to decrease the shrink force of the film. Factory setting is high.
- F. **CAUTION: When turning off the tunnel, be sure to turn off by means of the heater bank switch. The tunnel will automatically shut off at about 180 degrees.** (Temperature will be displayed on temperature controller at this time.) Turn off the start switch and then the main breaker located in the back of the tunnel.

**ST-1808-44 Tunnel Service Manual**

---

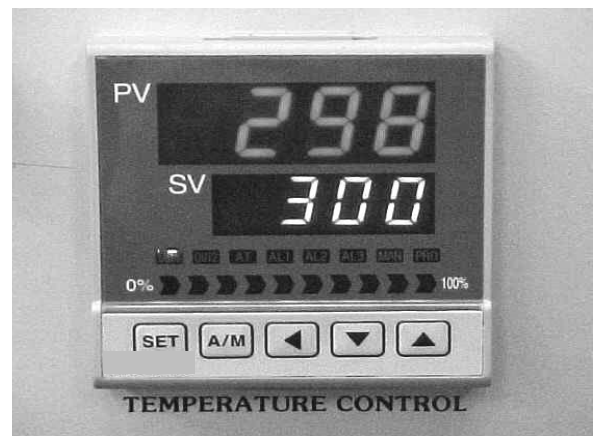
**Temperature Control Adjustment**

PV = Present Value  
SV = Set Value

On the above temperature controller the set value is 300 degrees and its present temperature is at 298 degrees.

**To Adjust Temperature Up or Down:**

First you must press the arrow key that points left (←). When pressing this key the set value temperature will flash first in the ones column. While flashing, you may adjust temperature by now pressing the arrow keys either up or down (↑↓) to the desired temperature in the ones column. Repeat this procedure by pressing the left arrow (←) to move flashing light to the tens column or the hundreds column and adjust up or down to desired temperature. Once you have adjusted to desired temperature press the set key and the temperature will now become your new set value (SV).

**ST-1808-44 Tunnel Service Manual**

---

**TROUBLESHOOTING**

The following troubleshooting section is provided to aid in determining the source of any operation difficulties which may develop. In performing tests and checks which follow, carefully inspect for any loose components, broken or loose wires, poor electrical connections, etc., while testing the various switches, controls, relays, transformers, etc. For checking electrical problems, use a voltage meter.

**Note:** While troubleshooting, use caution to avoid danger of electrical shock. When power is not required for checking for the presence of value of voltages used, always have it disconnected.

Refer to electrical components placement sheet and electrical schematic diagrams to assist in all troubleshooting efforts.

**DISCONNECT ALL POWER BEFORE MAKING ANY REPAIRS.**

**REFER TO ELECTRICAL BOARD LAYOUT AND  
ELECTRICAL SCHEMATIC (Page 53)  
FOR LOCATION OF ELECTRICAL COMPONENTS**

ST-1808-44 Tunnel Service Manual

**TROUBLE SHOOTING**

**Conveyor malfunction**



1. Check main power at machine's main breaker.

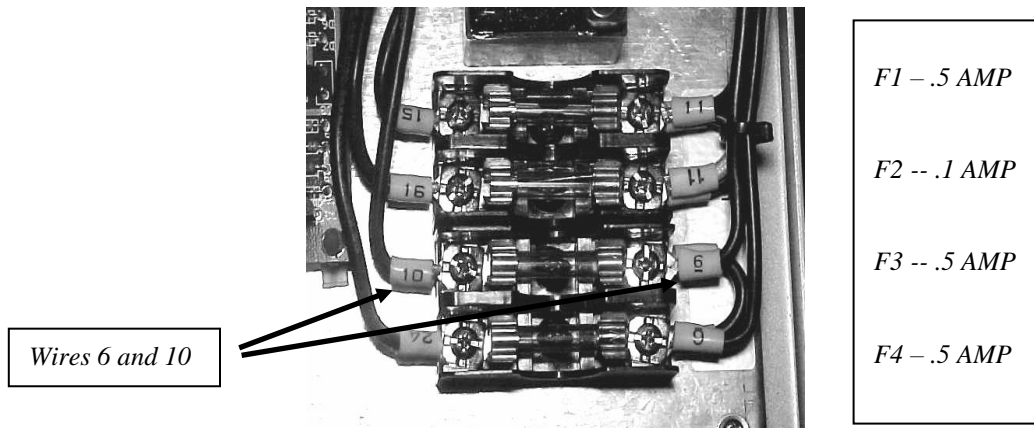

2. Open main panel. Check conveyor motor fuse (F-3/.5 Amp) wires No.6 and 10. If bad, replace.

**ST-1808-44 Tunnel Service Manual**

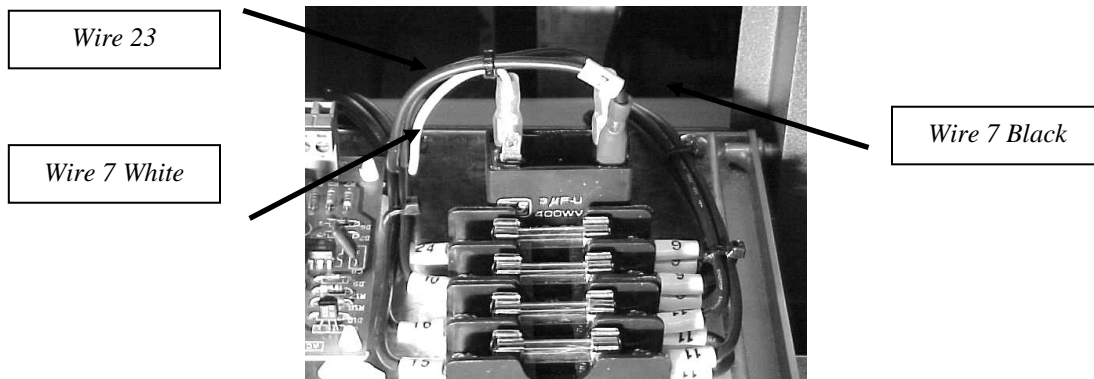

3. Check Motor Capacitor 1.5 mf. Make sure wires #7 (black) #7 (white) and 23 are connected to Capacitor. Check to see if Capacitor is burned.

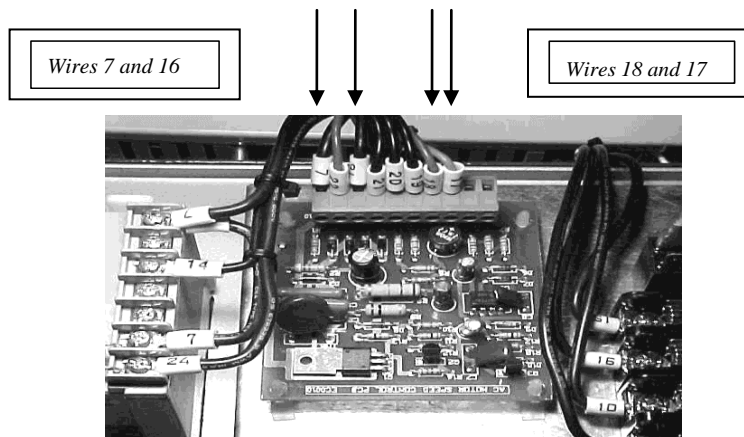

4. Check incoming power on AC Control Board 220 volt, Wires 7 and 16 (Pins 8 and 10). If no power present replace AC board.
  - (a) Check to make sure AC Board is not burned or damaged.
  - (b) If power is present at both locations 7 and 16 and motor does not operate, replace conveyor motor.

**ST-1808-44 Tunnel Service Manual**

---

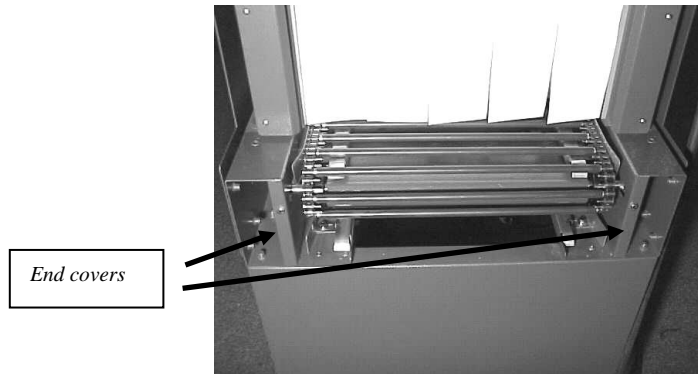

5. Remove end covers and look for obstructed product or lodged rollers.
  - (a) Check lubrication of conveyor chains.

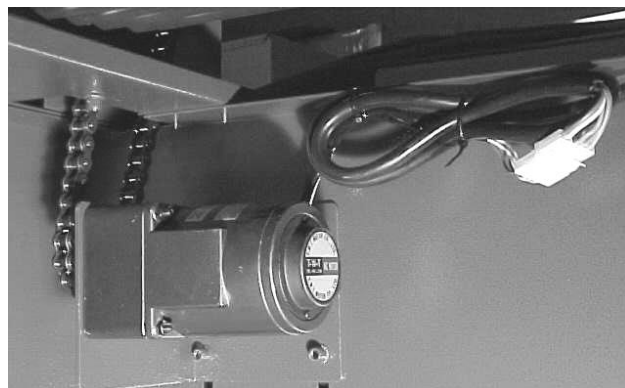

6. Make sure the connection wire on the motor and cable are not loose.
  - (a) Refer to electrical schematic on page 53 for proper wiring of the motor.
  - (b) Check wires 7 and 16 for power. If power present and motor does not operate, replace motor.

ST-1808-44 Tunnel Service Manual



7. Check to make sure the chain is not loose and the sprockets are not touching the frame.
  - (a) Replace the motor if all the above checks properly. See Maintenance, page 40.

**NO AIR FLOW**



1. Make sure air velocity knob is not on low.

ST-1808-44 Tunnel Service Manual

---

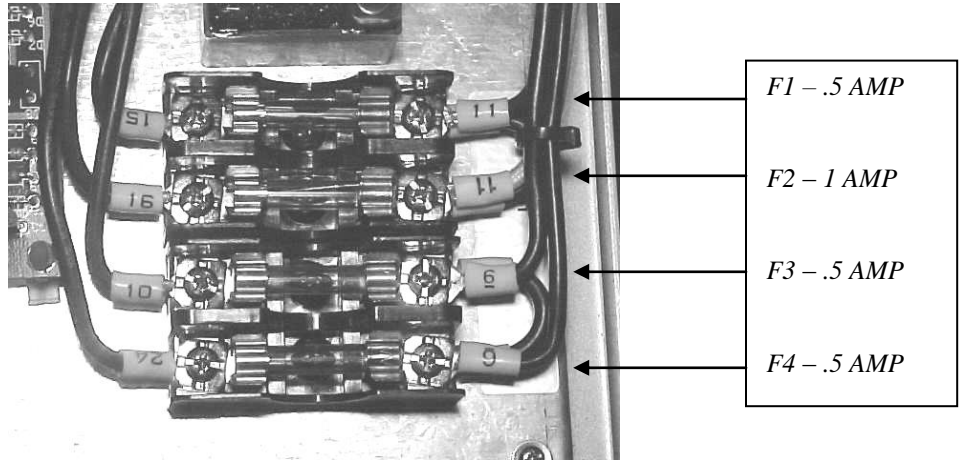

2. Open main electrical panel. Check Blower Motor fuse F-1 (.5 AMP).
3. Test fuses F1, F2, F3 and F4.



4. Check to make sure no air holes are obstructed due to plastic build up covering air holes.

**ST-1808-44 Tunnel Service Manual**

---

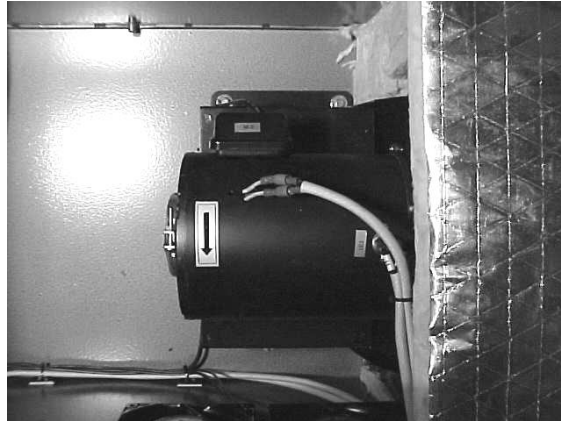

5. Check main blower motor and replace if necessary.
  - (a) Check motor start capacitor (M2) to see if burned.
  - (b) Check rotation of motor. Compare with arrow direction and make sure motor is turning in the same direction.
  - (c) Check motor wires 7 and 10 for loose connection.
  - (d) Check for 220 volt power across wires 7 and 10 (motor wires). If voltage is present and the motor still does not operate, replace motor.

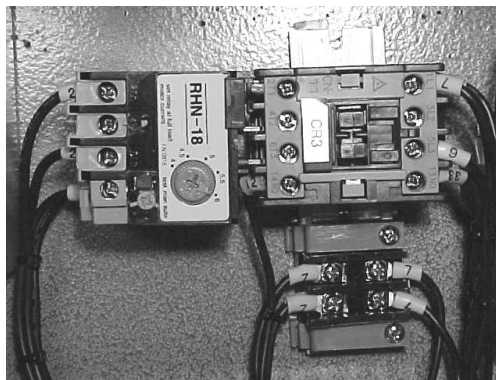

6.
  - (a) Check motor contactor.
  - (b) Check OL-1 motor overload contactor. Factory setting 5.5 to 6.0.

**ST-1808-44 Tunnel Service Manual**

---



7. Check to make sure blower wheel is not loose on the blower motor shaft.

**ST-1808-44 Tunnel Service Manual**

---

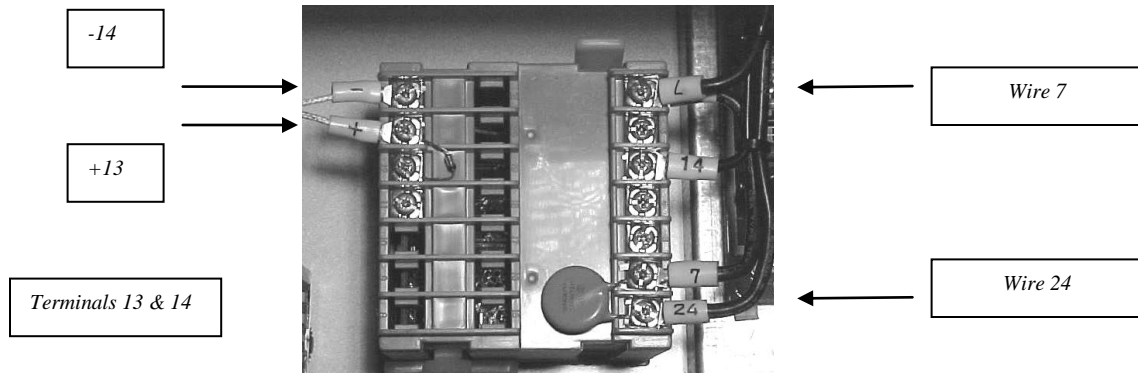
**NO HEAT**

1. Check thermocouple wires at temperature controller (Terminals +13 and -14). First, disconnect, then check with meter for continuity across the two thermocouple wires.
  - (a) If no continuity is present across thermocouple wires, replace thermocouple.
  - (b) Check terminals at 7 and 1 (wires 7 and 24) for 220 Volt power on temperature controller when CR2 is pulled in under set temperature.
  - (c) Check for 220 volt present with heater switch in on position. If no power is present, check Fuse F4, .5 AMP. If voltage present at wires 7 and 24 and Fuse F4 is good, replace Temperature Control.

ST-1808-44 Tunnel Service Manual

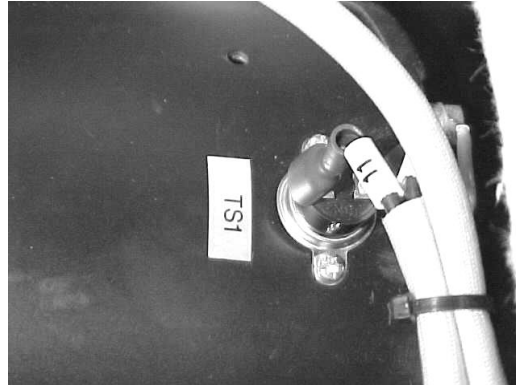

2. **Please note: Before replacing the Temperature Control, check the TS1 (TS1 NO open; thermo overload for blower motor) and TS2 (TS2 NC closed; heat cool down sensor) for continuity with the lead wires disconnected from sensor.**

**Note:** When any of the sensors are not functioning properly, this causes the temperature controller to malfunction.

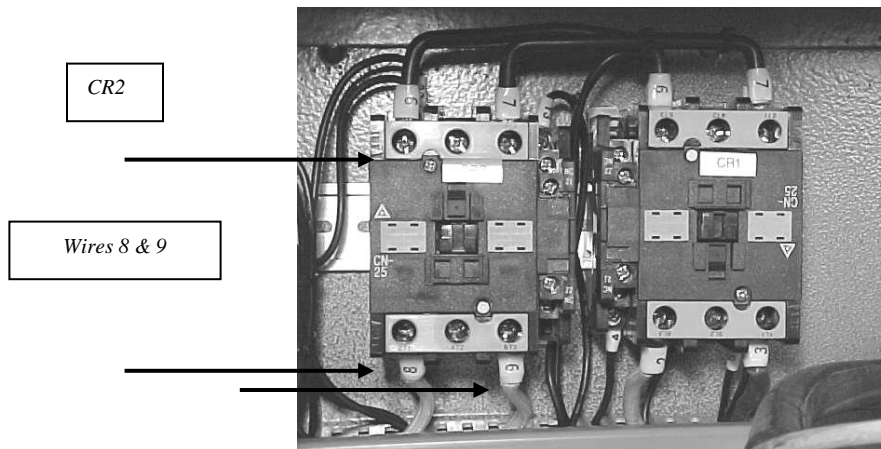

- (a) Check for 220 volt on wires 8 and 9 on CR2 with CR2 contactor pulled in under set temperature. If voltage is present on CR2 contactor on wires 8 and 9, check the Heat Bank for broken lugs or wire inside the Heater Bank. If leads and jumper wires on Heater Bank are not broken or burned, then replace the Heater Bank.

**ST-1808-44 Tunnel Service Manual**

---

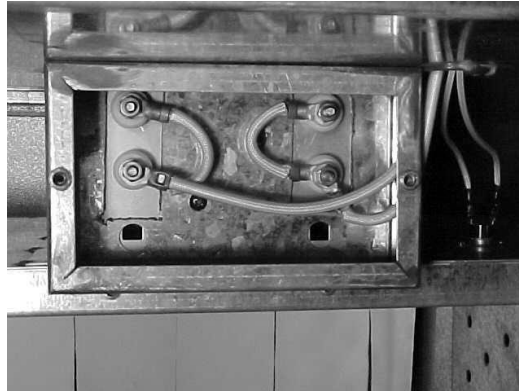

- (b) Check Heater Bank for replacement. Make sure no lugs on the Heater Bank have been broken.



3. Check the heater bank to make sure the wires are not loose or broken on the heater bank. Pull the heater bank and make sure the heater bank has continuity across wires. If not, replace it.

**ST-1808-44 Tunnel Service Manual**

---

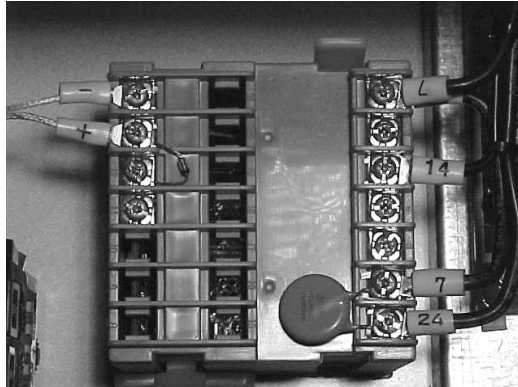

4. If no control over heat, interchange thermocouple wires at temperature controller. If still no control, check for replacement of CR2 or temperature control.

**ST-1808-44 Tunnel Service Manual**

---

**MAINTENANCE**

To aid in maintaining the high reliability of this shrink tunnel, the following maintenance should be provided.

**DISCONNECT ALL POWER BEFORE MAKING ANY REPAIRS.  
IF UNSURE OF ANYTHING, CONTACT  
A QUALIFIED SERVICE TECHNICIAN**

- A. The conveyor chains should be lubricated once a month with a high temperature oil. The lubricant should be applied with a brush or sprayed while the conveyor is slowly running.
- B. The silicone covering on the tunnel rollers should be inspected regularly to assure that no scrap pieces of film are wrapped around the rollers to cause sticking of packages. To clean, run conveyor until the affected rollers are within the heated chamber, thus heating the film residue to soften the film, then advance the conveyor to stop the rollers outside the heat chamber for cleaning. Make sure the conveyor is stopped before putting your hands or anything else in the conveyor area. If necessary to remove the film residue, use a dull, blunt-edged tool. Do not use any sharp instruments, as nicking the silicone may result in having to replace the roller covering.

To replace silicone covering on the roller proceed as follows:

**ST-1808-44 Tunnel Service Manual**

---

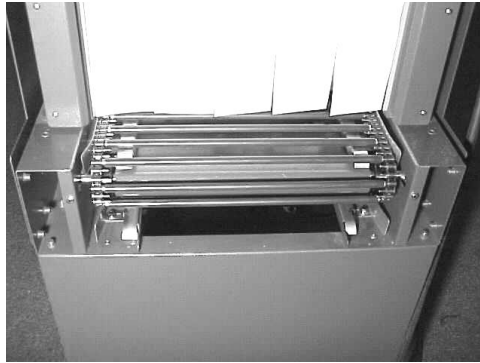
**Replacement of Conveyor Rollers**

- D. Remove idler end caps.

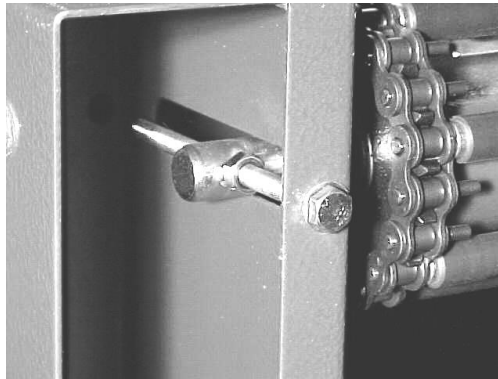

- E. Loosen the two take up bolts for the chain adjustment giving yourself enough slack to pull chain upward and spread chain apart to remove roller. See picture on page **38**.

**ST-1808-44 Tunnel Service Manual**

---



Now you are ready to move the rollers.

- F. Remove old roller covering by very carefully slitting the covering and pulling off.
- G. Clean all rollers, using steel wool or a wire wheel. Make certain all rollers are smooth and free of residue or burrs.
- H. Fit the new silicone rubber tubing onto each roller and work on by hand at least 1/2". At the opposite end of the tubing, attach and secure an air supply hose of low pressure, maximum pressure 5 lbs. While the tubing is slightly expanded by the air pressure, push the tubing onto the roller. Be very careful to hold the roller at all times so it does not escape due to the air pressure.
- I. Replace rollers on conveyor by inserting roller end holes into the extended pins on the chain
- J. Check conveyor chain tension as described on page 37.

**ST-1808-44 Tunnel Service Manual**

---

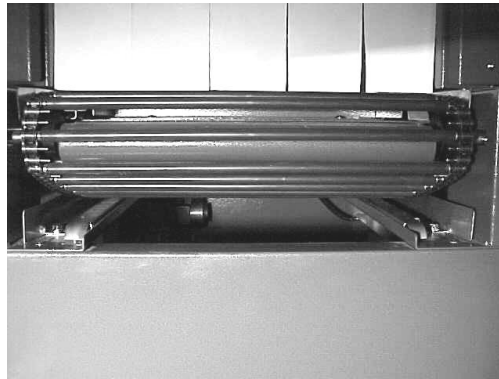

*Roller at 3 o'clock position*

- K. The adjustment of package conveyor chain tension should be checked occasionally to ensure that it is not excessive, as this would cause unnecessary wear of the sprockets. To check or adjust tension, shut off power to the tunnel. Remove idler end caps. Adjust conveyor to these specifications. On the idler end of the conveyor, bring a roller to the three o'clock position (the center of the end of the conveyor). From that point count seven roller in; the seventh roller should be evenly touching the conveyor roller bottom rails.

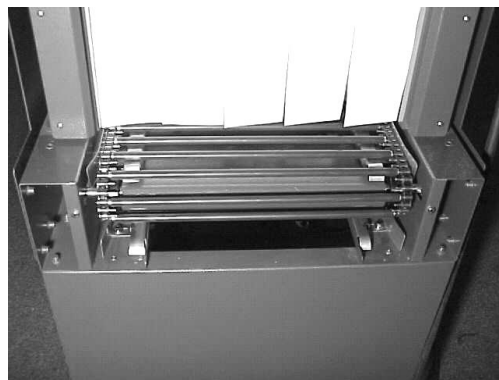

- L. **Replacement of idler roller shaft, bearings, or sprockets.** Remove idler end caps to gain access to idler shaft. Disconnect the conveyor chains by removing the master links. Remove two bolts from the idler block holder and shaft assembly should pull right out. Remove two tension bolts from

**ST-1808-44 Tunnel Service Manual**

---

idler block holder, then the shaft and sprockets will come right off. Replace and reassemble in the same manner as disassembled.

**ST-1808-44 Tunnel Service Manual**

---

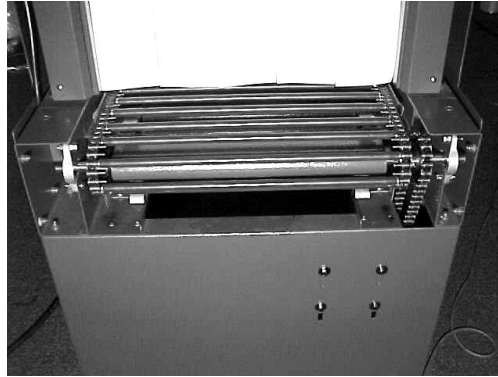
**M. Drive shaft, bearings, or sprockets replacement.**

- (1) Remove drive end caps instead of idler end caps.
- (2) Disconnect the conveyor chain by removing the master links.

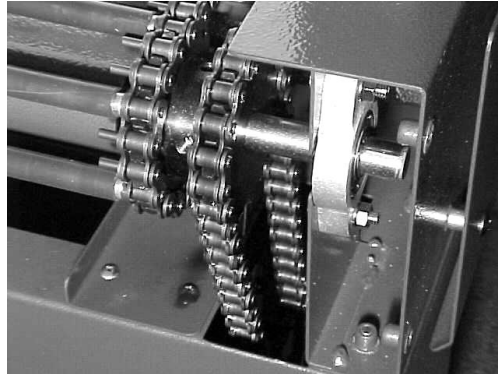

- (3) Remove two bolts from the flange bearings and remove drive shaft assembly.
- (4) The drive shaft has one sprocket pinned to it and must be reinstalled the same way. The other sprocket and bearings will slide right off the drive shaft. Replace and reassemble.

**ST-1808-44 Tunnel Service Manual**

---

**N. Conveyor motor replacement.**

- (1) Disconnect power to machine.
- (2) Disconnect electrical wires from drive motor, and remove four bolts that hold the drive motor.
- (3) Remove sprocket from old motor and place on new drive motor. Reassemble in the same manner it was disassembled. For wire hook up refer to electrical schematic on page 53.

**ST-1808-44 Tunnel Service Manual**

---

**O. Heater bank replacement.**

- (1) Shut off power to machine.

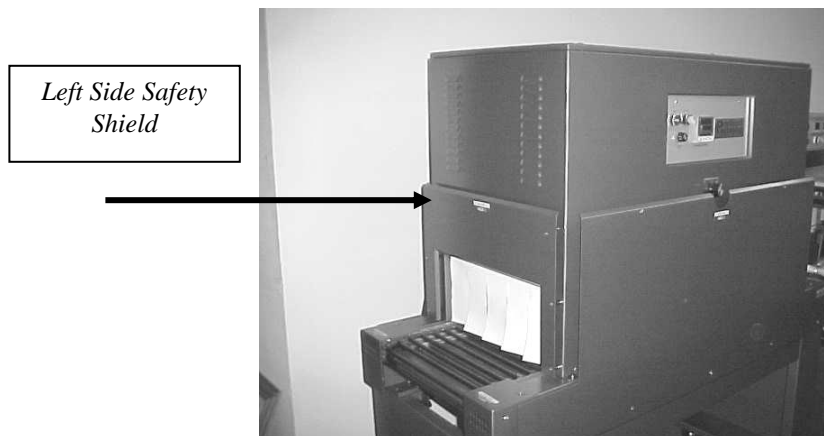

- (2) Remove left side safety shield and panel.

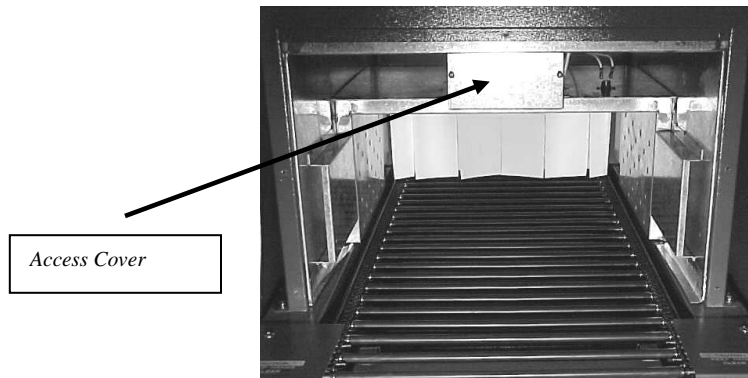

- (3) Remove access cover and pull insulation out.

**ST-1808-44 Tunnel Service Manual**

---



- (4) With a 3/8" nut driver, remove wires on the heater bank. Set wires off to side.
  - (a) Remove heater bank terminal box from the heater bank.



- (5) Then remove heater bank.
- (6) Place the heater bank terminal box on the new heater bank. Reassemble in the same manner it was disassembled.

**ST-1808-44 Tunnel Service Manual****P. Temperature controller replacement.**

- (1) Shut off power to machine.
- (2) Open main panel door.

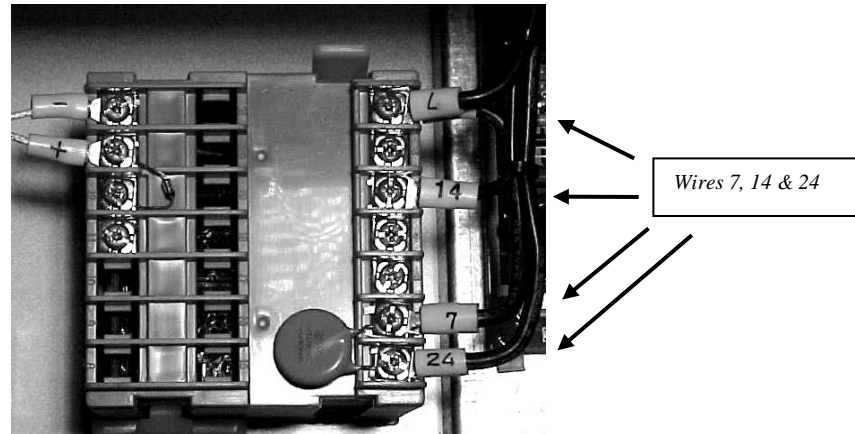

- (3) Disconnect four wires (Two Nos. 7, 14 and 24) and thermocouple wires from temperature controller.
- (4) Loosen screws on side of controller itself and pull controller out of the front of the panel. Replace with new controller. Refer to electrical schematic for replacement of four wires (Two Nos. 7, 14 and 24) and thermocouple wires.

**WARNING: IF NO CONTROL OVER HEAT, INTERCHANGE THERMOCOUPLE WIRES.**

**CAUTION! DO NOT EXCEED 500 DEGREES.**

**ST-1808-44 Tunnel Service Manual**

---

**Q. Blower Motor Replacement.**

1. Shut off power to machine.

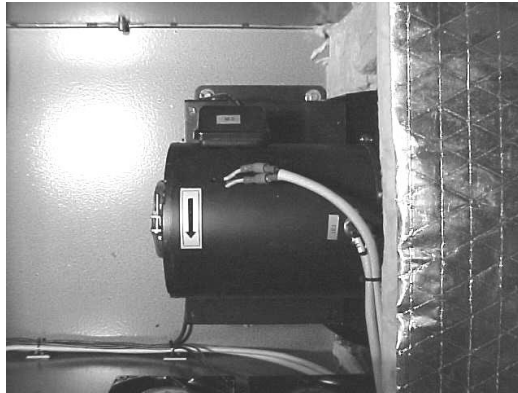

2. Remove top panel and 4 screws holding the blower chamber cover.
3. Disconnect wires on the blower motor.

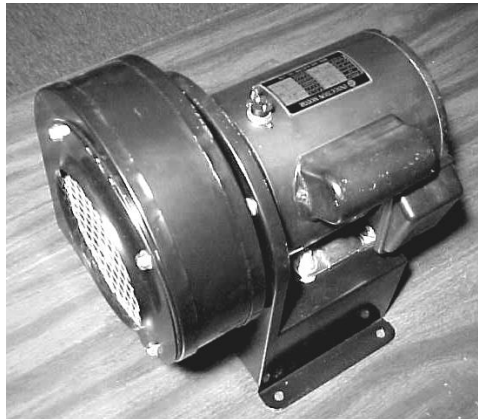

4. Remove four bolts at motor base.

ST-1808-44 Tunnel Service Manual

---



5. Once blower housing is on a bench, loosen the four bolts holding the blower wheel screen and remove screen.

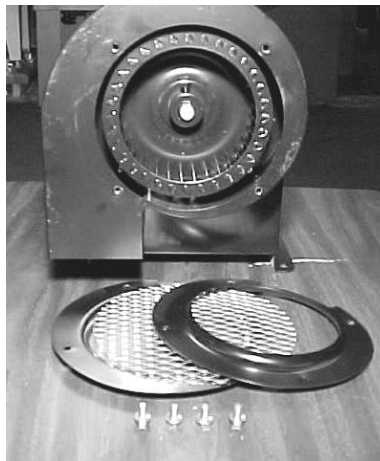

6. Remove outer screen covering of Blower Wheel Housing.



**ST-1808-44 Tunnel Service Manual**

---

6. Remove Bolt Holding Blower wheel to Blower Motor.

**Note:** This housing should be tested outside the tunnel to assure that it works. Reassemble in the same manner as disassembled. (If force is necessary, apply it between the motor and the blower wheel hub.) Now remove the motor mount bolts and remove/replace motor. Reassemble new motor and blower wheel housing.

**ST-1808-44 Tunnel Service Manual**

---

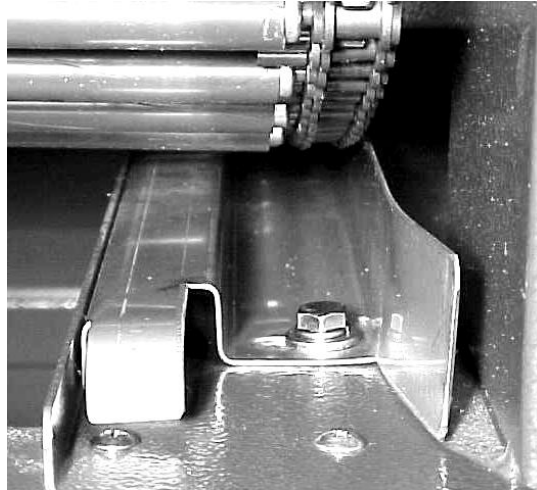
**R. Wear rails lower adjustments.**

1. Disconnect power to machine.
2. Remove idler and drive end caps. Loosen the two bolts holding each wear rail underneath conveyor, and slide rails over towards center. There should be 1/16" to a max. of 1/8" clearance between conveyor chain and roller. Retighten the two bolts.

**S. Wear rails lower replacement.**

1. Disconnect power to machine.
2. Remove idler and drive end caps.
3. Remove two bolts underneath conveyor from each wear rail and slide rails out.
4. Slide new rails in; reassemble and readjust.

**ST-1808-44 Tunnel Service Manual**

---

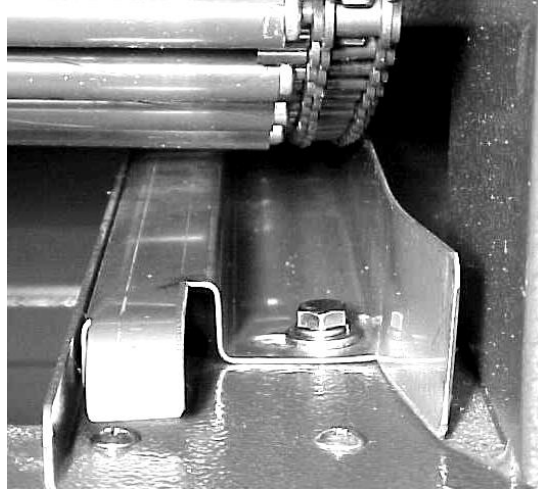

5. Wear rail should be 1/8" from edge of chain then tighten bolt to secure wear rails.
- T. **Wear rails upper adjustments.**
1. Disconnect power to machine.
  2. Remove drive and idler end caps.
- Note: Take out only ten rollers, then move the open space to one end. Loosen the one bolt that hold rail in place. With a screw driver, pry rail over towards the center. Do the same on all four corners. Spin conveyor by hand and check clearance between chain and roller. The distance should be about 1/16". Then tighten the two bolts on each rail.

**ST-1808-44 Tunnel Service Manual**

---

**U. Wear rail upper replacement.**

1. Disconnect power to machine.
2. Remove drive and idler end caps.

Note: Take out only top half of rollers, then move the open space to expose upper wear rails. Remove the two bolts that hold rails in place. Pull out rails and replace with new rails; reassemble and readjust.

**IF UNSURE OF ANYTHING, CONTACT A QUALIFIED SERVICE TECHNICIAN.**

**DOUBLE CHECK ALL OF YOUR WORK BEFORE STARTING THE MACHINE.**

ST-1808-44 Tunnel Service Manual

---

**ELECTRICAL PANEL  
DIAGRAM CONTROLS FOR  
ST-1808-44**

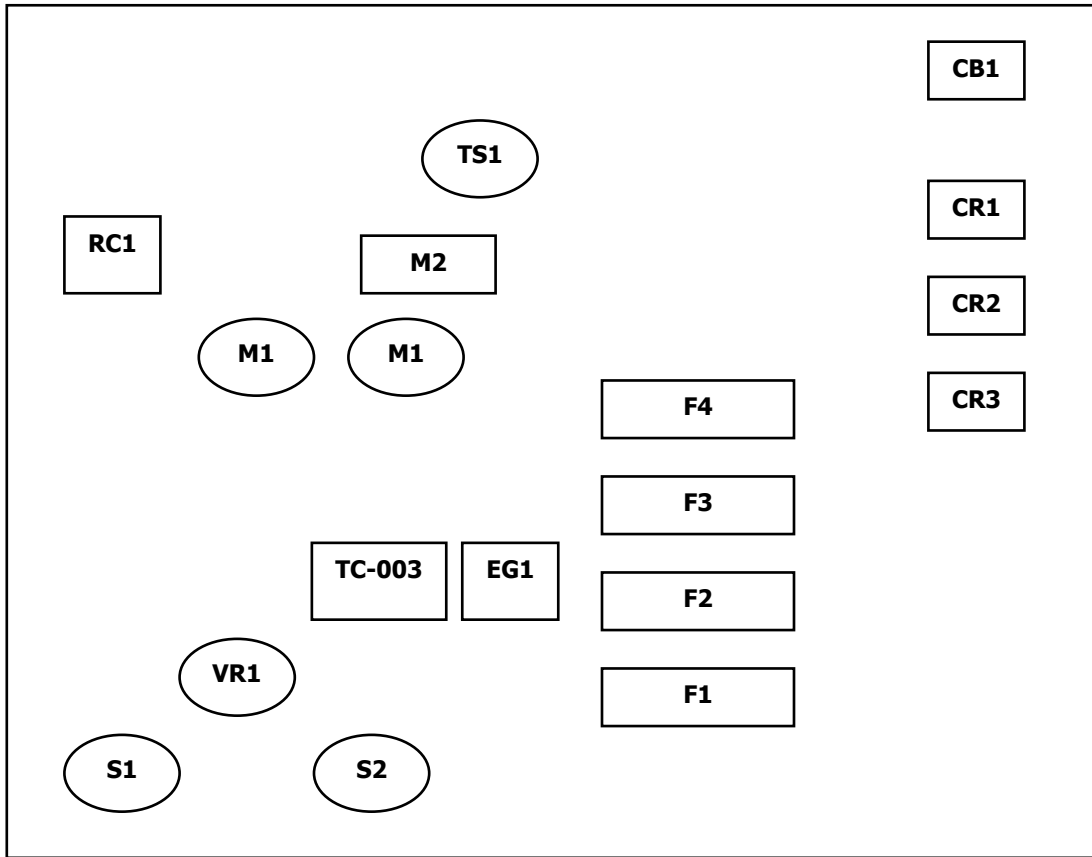

ST-1808-44 Tunnel Service Manual

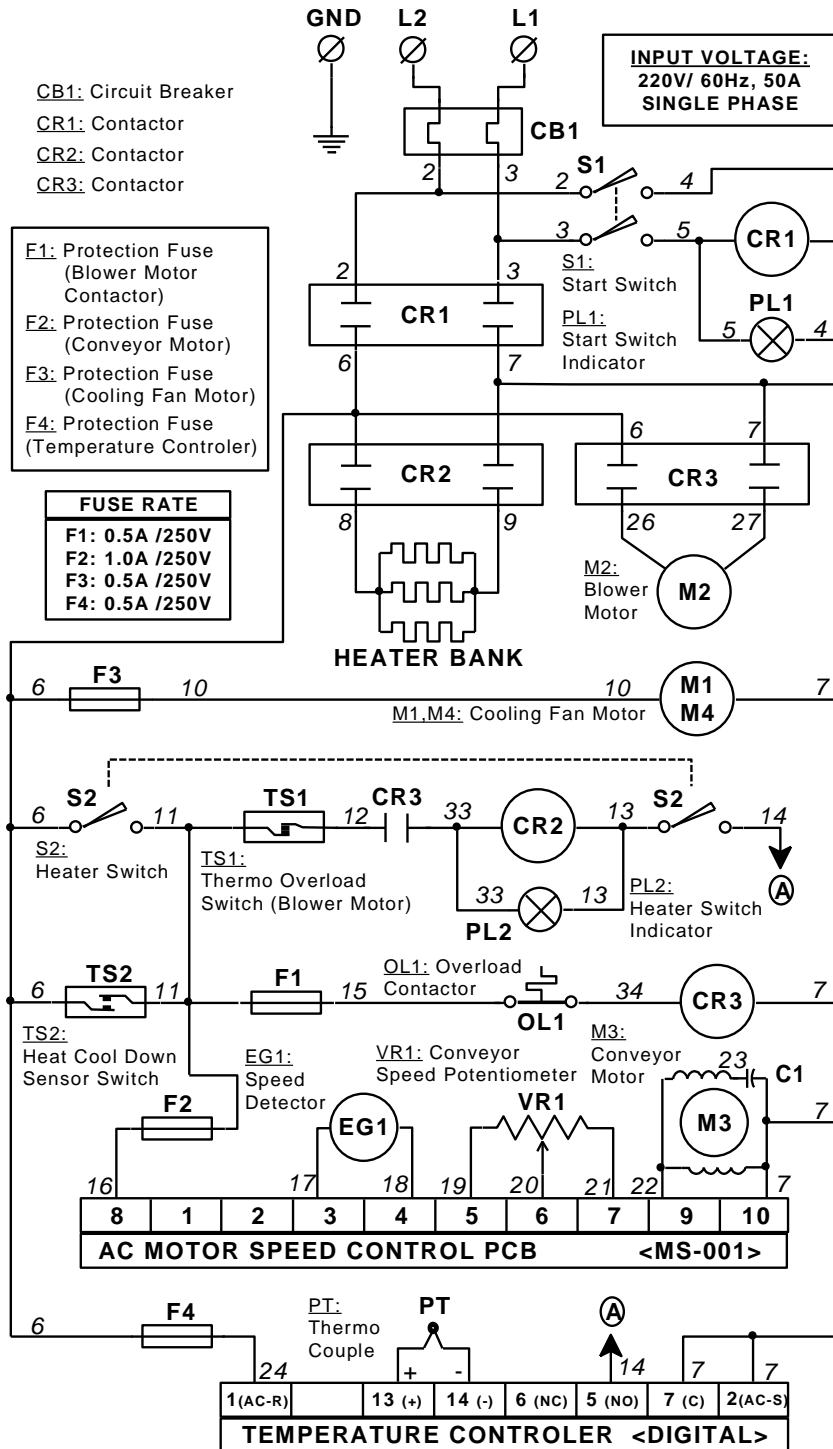

SHRINK TUNNEL MODEL: ST-1808-44 (220V)

**ST-1808-44 Tunnel Service Manual**

**MODEL ST-1808-44 TUNNEL**

Item	Part #	Qty	Parts List Nomenclature
F1, F3, F4	3500-14	3	.5 AMP
F2	3500-15	1	1 AMP
MS001	3500-12	1	AC Conveyor Motor Speed Control
ACT	3600-30	1	AC Terminal
RC1	3500-02	1	Capacitor, 3 MF, 400 VAC
CB1	3500-19	1	Circuit Breaker, 40 AMP
CR1	3400-13	1	Contacto – 3 Pole, 208/240 Volt, 50 AMP
CR2	3400-13	1	Contacto – 3 Pole, 208/240 Volt, 50 AMP
M3	3500-105-22	1	Conveyor Drive Motor AC (5GN20K 40W
M1 & M4	1722-37	2	Cooling Fan Motor
TS2	3500-46	1	Heat Cool Down Sensor (B-100)
Heater	1720-09	1	Heater Bank
M2	1748-36	1	Main Blower – 1 HP, 208-240 Volt
PL1	3600-05	1	Pilot Light 220 Volt Start Switch
PL2	3600-10	1	Pilot Light 220 Volt Start Switch
EG1	3500-25	1	Speed Control Conveyor Motor
VR1	3400-68	1	Speed Potentiometer – Conveyor Motor
S2	3600-25	1	Switch – Heater
S1	3600-20	1	Switch – Start
TC-003	3500-75	1	Temperature Controller
CR3	3448-15	1	CU-11 Contacto – 208/240 Volt
TS1	3600-35	1	Thermo Overload Sensor (A-100)
PT	3600-15	1	Thermocouple
OL1	RHU10	1	Overload Contacto

**ST-1808-44 Tunnel Service Manual**

<b>SHRINK TUNNEL REPLACEMENT PARTS</b>		
<b>Part #</b>	<b>Qty</b>	<b>Description</b>
3500-35	4	Adjustable Leveling Bolts
3500-36	2	Bearing – Drive Shaft Mounting
1748-36	1	Blower Motor 1 HP
3548-03	1	Blower Wheel
1722-37	2	Cooling Fan Motor
3500-04	4	Caster
3500-02	1	Capacitor, 3 MF, 400 VAC
3500-19	1	Circuit Breaker – 40 AMP
3500-05	2	Chain – Master Link #40 – Extended Pin
1722-24	1	Chain – Master Link #40
3500-37	2	Chain Tension Adjustment Bolt
3500-06	28	Chain -- #40 – Extended Pin – Conveyor (per ft.)
1722-23	1.5	Chain -- #40 – Rivited-Motor to Drive Shaft (per ft.)
3400-13	2	Contactora – 3 Pole – 50 AMP
3400-15	1	Contactora-3 pole 25 Amp
3528-07	1	Conveyor Belt – SS – Wire Mesh (Belt Only) – Optional
3528-05	1	Conveyor Belt – Teflon Mesh Belt (126") -- Optional
3528-01	1	Conveyor Belt – Mesh Belt Clamp Bar -- Optional
3500-105	1	Conveyor Drive Motor AC (5GN20K 40W 220V)
3528-10	2	Curtain Material Set (one end)
3500-11	1	Drive Shaft
3500-12	1	AC Electrical Board – Complete
3500-38	1	End Covers – Drive Side (Left)
3500-39	1	End Covers – Drive Side (Right)
3500-40	1	End Covers – Idler Side (Left)
3500-41	1	End Covers – Idler Side (Right)
3500-14	1	Fuse F1 -- .5 AMP
3500-42	1	Fuse – F2 1 AMP
3500-43	1	Fuse – F3 .5 AMP
3500-44	1	Fuse – F4 .5 AMP
3500-16	1	Fuse Block

**ST-1808-44 Tunnel Service Manual**

<b>SHRINK TUNNEL REPLACEMENT PARTS</b>		
<b>Part #</b>	<b>Qty</b>	<b>Description</b>
3400-31	1	Fuse Holder
3500-45	1	Heater Bank – Mounting Box
1720-09	1	Heater Bank – 9 KW
3500-46	1	Heat Sensor – B-100 NC—Tunnel Cool Down – TS2
3500-35	1	Heat Sensor – S-90 NC Thermal Overload Blower Motor – TS1
1721-18		Hole Plug Buttons – 3/8” – Nickel
3500-47	1	Housing – Blower Motor
3500-17	1	Idler Shaft
3500-48	8	Lugs – High Temperature Heater Wire
3600-05	2	Pilot Light – 220 Volt
3500-49	1	Power Cord – 10 feet
3500-50	1	Power Cord Connector
3500-51	2	Rails – Upper/Wear Rails
3500-52	2	Rails – Lower Wear Rails
3500-23	82	Roller 16” -- Covered (Hi density 122)
3500-53	1	Safety Shield – Right End
3500-54	1	Safety Shield – Left End
3500-55	1	Safety Shield – Front
3500-56	1	Safety Shield – Back
3500-57	6	Safety Shield – 1” End Spacer
3500-58	2	Safety Shield – Front/Back Spacer 1 ½”
3500-59	5	Front/Back Spacer ½”
3500-60	5	Front/Back Mount Screw 1”
3500-61	6	Safety Shield – End Mounting Screw 1 ½” L
3500-62	2	Safety Shield – Front/Back Mounting Screw 2”
3500-63	6	Screw – Tunnel Hood Top 10 mm
3500-64	1	Screen – Blower Wheel
3500-65	1	AC Speed Control Potentiometer
3500-26	2	Sprocket – Conveyor Drive
3500-27	2	Sprocket – Conveyor Idler with Bearing
3500-28	1	Sprocket – Conveyor Motor

**ST-1808-44 Tunnel Service Manual**

<b>SHRINK TUNNEL REPLACEMENT PARTS</b>		
<b>Part #</b>	<b>Qty</b>	<b>Description</b>
3500-20	1	Switch – Start S1
3500-21	1	Switch – Heater Bank S2
3600-30	1	Switch – Delay cool down thermos switch
3500-29	1	Thermocouple Probe Holder
3500-30	1	Thermocouple Probe
3500-75	1	Temperature Controller
3400-79	1	Terminal Strip – Short – 3 Lug
3500-31	1	Velocity Control Knob
3500-32	1	Velocity Control Shaft
3500-70		Wire – High Temperature
3600-35	1	Thermo Overload Sensor (A-100) TS1

**ST-1808-44 Tunnel Service Manual**

**Spare Parts List  
ST-1808-44 Shrink  
Tunnel**

<b>Item #</b>	<b>Part #</b>	<b>Description</b>	<b>Qty.</b>	<b>Price</b>
1	3500-14	.5A Fuse	2	
2	3500-15	10A Fuse	2	
3	3500-21	Heater Switch	1	
4	LU0855	Lubricant – Chain	1	
5	3500-46	Cool Down Sensor (B-100)	1	
6	1720-05	Heater Bank 10 KW	1	
7	3500-75	Temperature Controller	1	
8	3500-20	Start Switch	1	
9	3500-30	Thermocouple Probe	1	
10	3600-35	Thermo overload sensor (S-90)	1	
<b>Total Cost</b>				

01/14/00